

Features

- Metal silicon junction, majority carrier conduction
- For surface mounted applications
- Low power loss, high efficiency
- For use in low voltage, high frequency inverters, free wheeling, and polarity protection applications

Mechanical Data

- Case: SOD-323HE
- Terminals: Solderable per MIL-STD-750, Method 2026
- Approx. Weight: 5.4mg/0.00019oz

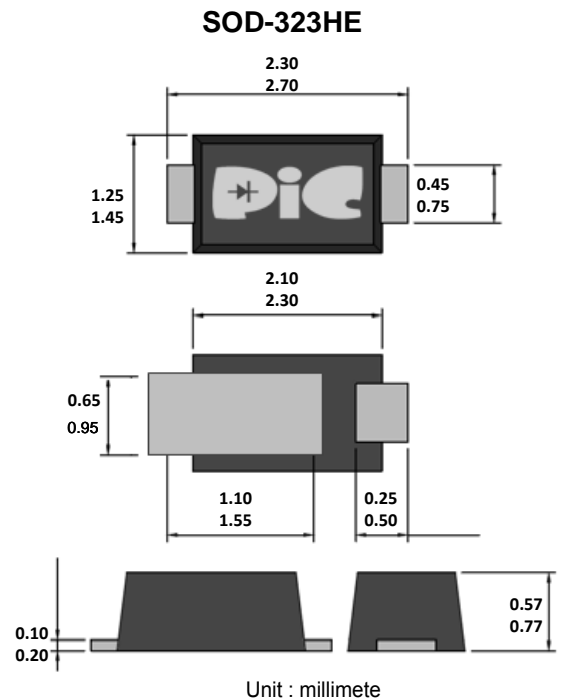

Absolute Maximum Ratings and Electrical characteristics

Parameter	Symbols	SS1040LHSW	Units
Maximum Repetitive Peak Reverse Voltage	V_{RRM}	40	V
Maximum RMS voltage	V_{RMS}	28	V
Maximum DC Blocking Voltage	V_{DC}	40	V
Maximum Average Forward Rectified Current	$I_{F(AV)}$	1.0	A
Peak Forward Surge Current, 8.3ms Single Half Sine-wave Superimposed on Rated Load (JEDEC method)	I_{FSM}	25	A
Max Instantaneous Forward Voltage at 1 A	V_F	0.47	V
Maximum DC Reverse Current at Rated DC Reverse Voltage	I_R	0.5 20	mA
Typical Junction Capacitance ⁽¹⁾	C_j	160	pF
Typical Thermal Resistance ⁽²⁾	$R_{\theta JA}$	150	°C/W
Operating Junction Temperature Range	T_j	-55 ~ +125	°C
Storage Temperature Range	T_{stg}	-55 ~ +150	°C

(1) Measured at 1 MHz and applied reverse voltage of 4 V D.C

(2) P.C.B. mounted with 8X 8 mm copper pad areas.

Rating and Characteristics Curves

Fig.1 Forward Current Derating Curve

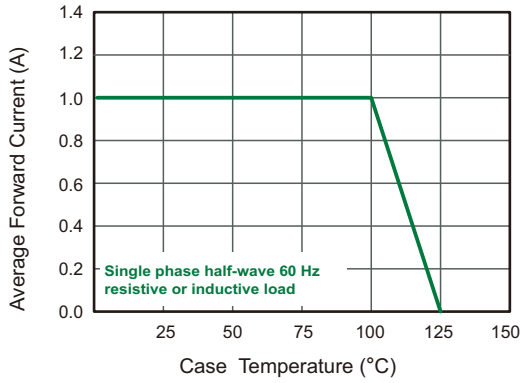

Fig.2 Typical Reverse Characteristics

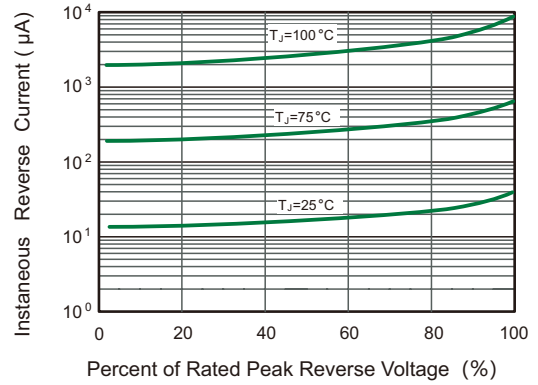

Fig.3 Typical Forward Characteristic

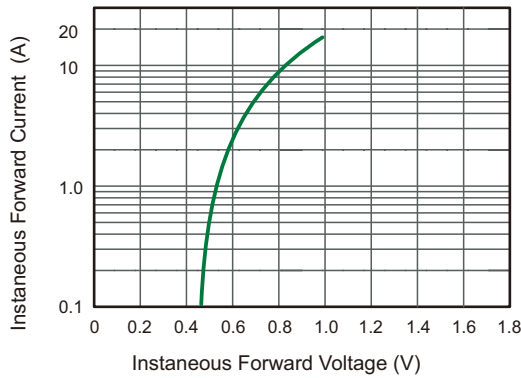

Fig.4 Typical Junction Capacitance

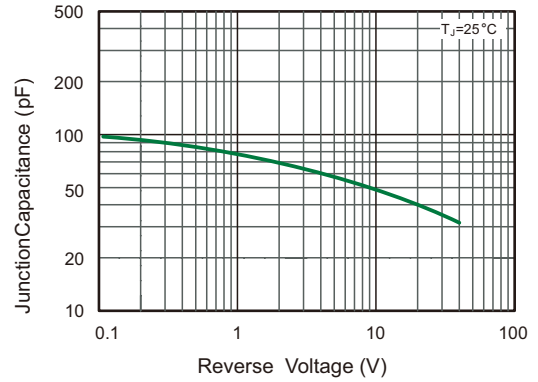

Fig.5 Maximum Non-Repetitive Peak Forward Surge Current

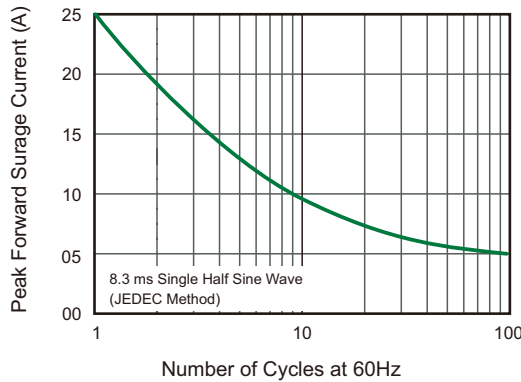
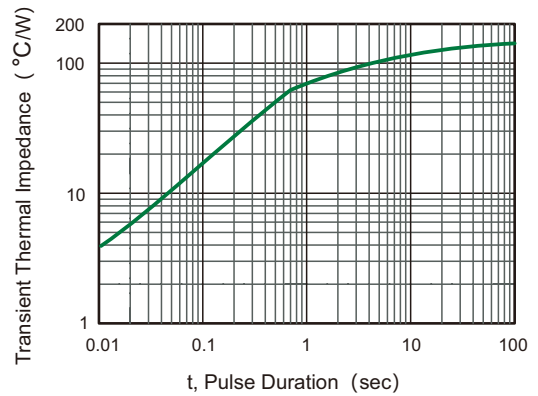
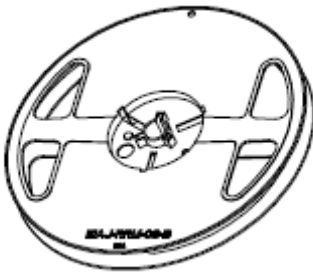
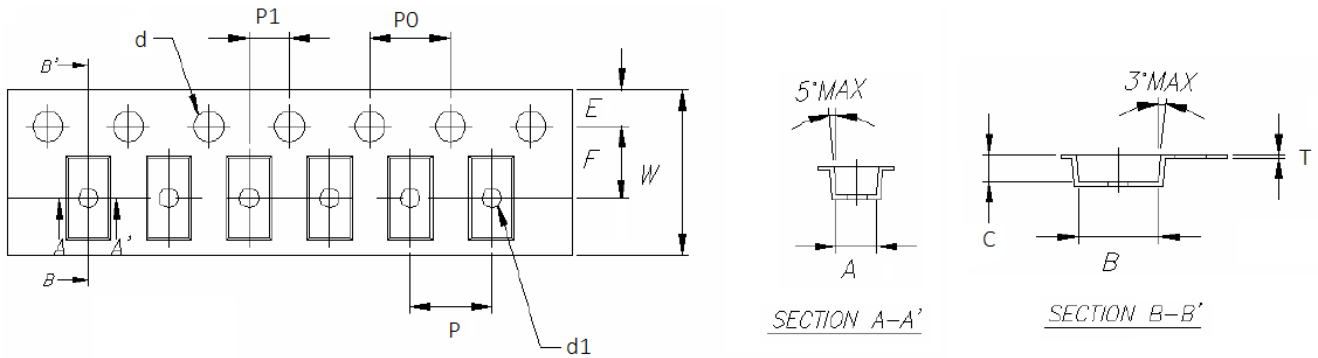

Fig.6 Typical Transient Thermal Impedance



Packaging Specifications

Package	W (mm)	A (mm)	B (mm)	C (mm)	d1 (mm)	d (mm)	E (mm)	F (mm)	P (mm)	P0 (mm)	P1 (mm)	T (mm)
SOD-123FL	8±0.2	2.00±0.1	3.85±0.1	1.1±0.1	1.0	1.50±0.1	1.75±0.1	3.5±0.05	4±0.1	4±0.05	2±0.05	0.23±0.05
SOD-123HE	8±0.3	2.00±0.1	4.00±0.1	1.45±0.1	1.0	1.55±0.1	1.75±0.1	3.5±0.05	4±0.1	4±0.10	2±0.05	0.23±0.10
SOD-323FL	8±0.2	1.37±0.1	2.75±0.1	0.85±0.1	1.00	1.60±0.1	1.75±0.1	3.50±0.05	4±0.1	4±0.10	-	0.20±0.10
SOD-323HE	8±0.3	1.60±0.1	2.80±0.1	0.95±0.1	1.0	1.50±0.1	1.75±0.1	3.5±0.05	4±0.1	4±0.10	2±0.05	0.23±0.10
SMAF	12±0.3	2.9±0.1	5.5±0.1	2.1±0.1	1.5	1.55±0.1	1.75±0.1	5.5±0.05	4±0.1	4±0.10	2±0.05	0.23±0.10
SMA-S	12±0.2	2.65±0.1	5.25±0.1	1.35±0.1	1.0	1.55±0.1	1.75±0.1	5.5±0.05	4±0.1	4±0.05	2±0.05	0.23±0.10
SMA-HE	12±0.2	2.65±0.1	5.25±0.1	1.35±0.1	1.0	1.55±0.1	1.75±0.1	5.5±0.05	4±0.1	4±0.05	2±0.05	0.23±0.10



Package	D (max.) (mm)	D1 (min.) (mm)	D2 (mm)	G (min.) (mm)	W1 (min.) (mm)
SOD-123FL	178	50.0	13.0±0.2	8.4	11.4
SOD-123HE	178	50.0	13.0±0.2	8.4	11.4
SOD-323FL	178	50.2	13.0±0.2	8.0	11.5
SOD-323HE	178	50.0	13.0±0.2	8.4	11.4
SMAF	178	50.0	13.0±0.2	12.4	18.0
	330	50.0	13.0±0.2	12.4	18.0
SMA-S	178	50.0	13.0±0.2	12.4	18.0
SMA-HE	178	50.0	13.0±0.2	12.4	18.0

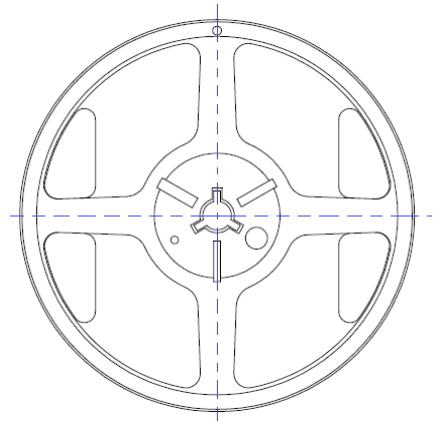
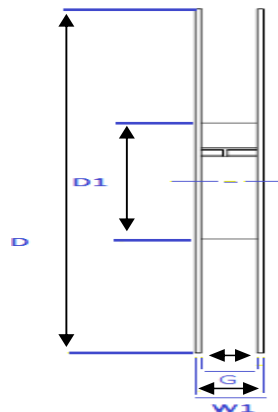
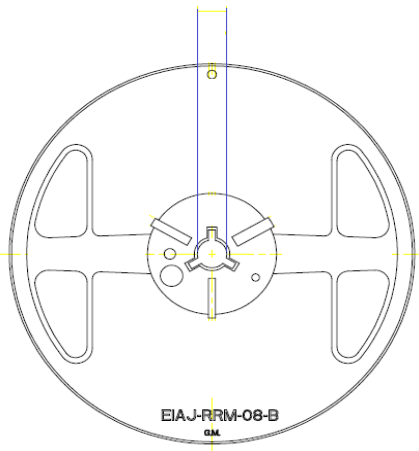

PACKAGE OUTLINE SOD-323HE

Plastic surface mounted package; 2 leads

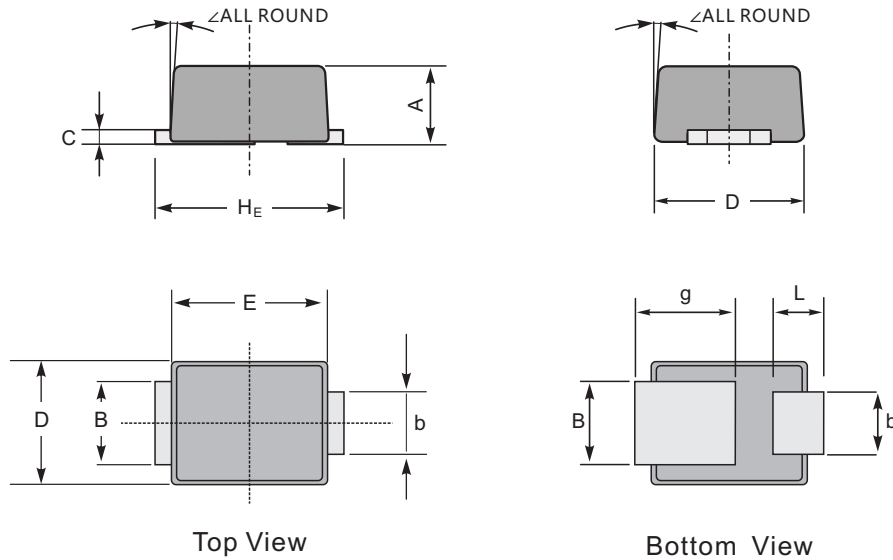

UNIT		A	b	B	C	D	E	H _E	g	L	\angle
mm	max	0.77	0.75	0.95	0.20	1.45	2.3	2.7	1.55	0.50	12°
	min	0.57	0.45	0.65	0.10	1.25	2.1	2.3	1.1	0.25	
mil	max	30	30	37	8	57	91	106	61	20	
	min	22	18	26	4	49	83	91	43	10	

The recommended mounting pad size

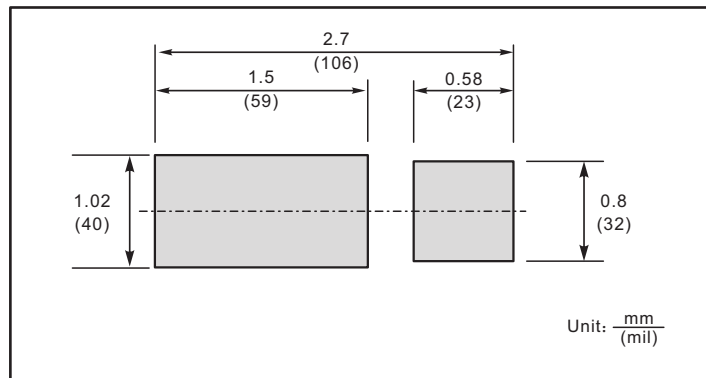

Ordering Information

Part Number	Description	Quantity
SS1040LHSW	SOD-323HE Reel	3,000 pcs

Recommend IR Reflow Soldering Thermal Profile

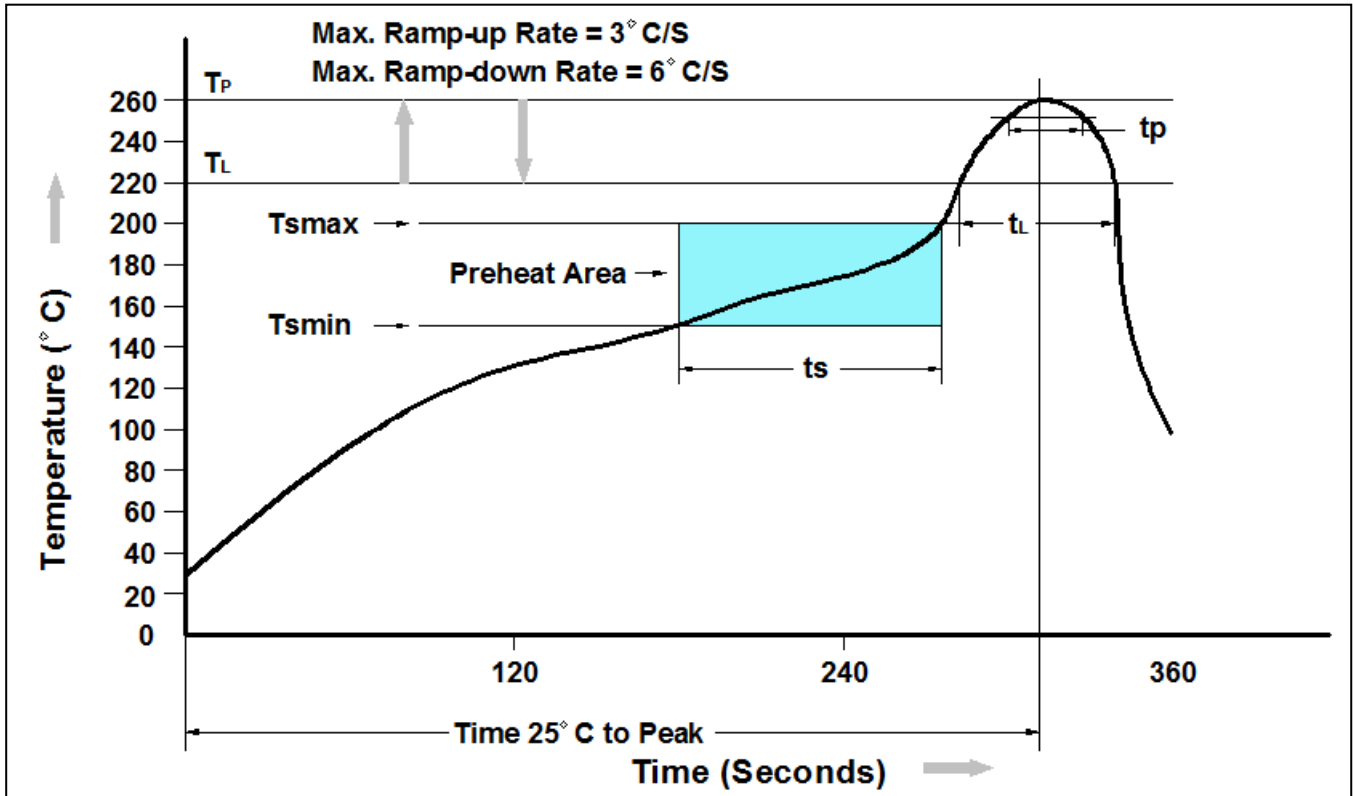

Profile Feature	Pb-Free Assembly Profile
Temperature Min. (T Amin)	150°C
Temperature Max. (Tsmax)	200°C
Time (ts) from (T Amin to Tsmax)	60-120 seconds
Average Ramp-up Rate (tL to tP)	3°C/second max.
Liquidous Temperature (TL)	217°C
Time (tL) Maintained Above (TL)	60 – 150 seconds
Peak Temperature	260°C +0°C / -5°C
Time (tP) within 5°C of actual Peak Temperature	30 seconds
Ramp-down Rate (TP to TL)	6°C/second max
Time 25°C to Peak Temperature	8 minutes max.

DISCLAIMER

- The information in this document and any product described herein are subject to change without notice and should not be construed as a commitment by Paceleader, Paceleader reserve the right to make changes to the information in this document.
- Though Paceleader make effort to improve product quality and reliability, Product can malfunction and fail due to their inherent electrical sensitivity and vulnerability to physical stress, it is the responsibility of the customer, when utilizing Paceleader products, to comply with the standards of safety in making a safe design for entire system and to avoid situation in which a malfunction or failure., In developing a new designs, customer should ensure that the device which shown in this documents are used within specified operating ranges.
- The information contained herein is presented only as a guide for the applications of our products. No responsibility is assumed by Paceleader for any infringements of patents or other rights of the third parties which may result from its use.