

➤ General Description

The SMF05C TVS arrays are designed to protect sensitive electronics from damage or latch-up due to ESD and other voltage-induced transient events. They are designed for use in applications where board space is at a premium. Each device will protect up to five lines. They are unidirectional devices and may be used on lines where the signal polarities are above ground. TVS Diode Array For ESD and Latch-Up Protection

➤ Feature

- Protects five I/O lines
- Low capacitance
- Working voltages : 5V
- Low leakage current
- Response Time is < 1 ns
- Low operating and clamping voltages
- Solid-state silicon avalanche technology
- Device Meets MSL 1 Requirements
- ROHS compliant

➤ SOT-363

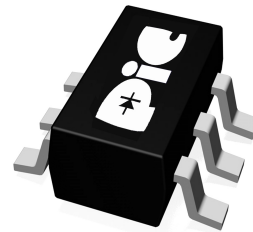

➤ Application

- Cellular Handsets and Accessories
- Cordless Phones
- Personal Digital Assistants (PDA's)
- Notebooks and Handhelds
- Portable Instrumentation
- Digital Cameras
- Peripherals

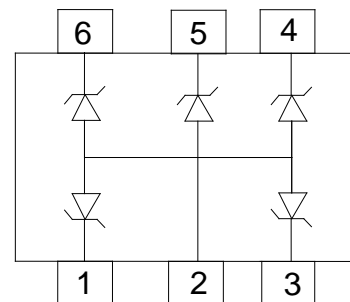

➤ Protection solution to meet

- IEC61000-4-2 (ESD) $\pm 15\text{kV}$ (air), $\pm 8\text{kV}$ (contact)
- IEC61000-4-4 (EFT) 40A (5/50ns)

➤ Maximum Ratings (TA=25°C Unless otherwise specified)

Parameter	Symbol	Value	Unit
Peak Pulse Power (tp=8/20μs waveform)	P _{PPP}	50	Watts
Peak Pulse Current(tp=8/20μs waveform)	I _{PP}	2.5	A
ESD Rating per IEC61000-4-2:	Contact	8	KV
	Air	15	
Lead Soldering Temperature	T _L	260 (10 sec.)	°C
Operating Temperature Range	T _J	-55 ~ 150	°C
Storage Temperature Range	T _{STG}	-55 ~ 150	°C

Maximum ratings are those values beyond which device damage can occur. Maximum ratings applied to the device are individual stress limit values (not normal operating conditions) and are not valid simultaneously. If these limits are exceeded, device functional operation is not implied, damage may occur and reliability may be affected.

*Other voltages may be available upon request.

1. Non-repetitive current pulse, per Figure 1.

➤ Electrical Characteristics (TA=25°C Unless otherwise specified)

Symbol	Parameter	Conditions	Min.	Typ.	Max.	Units
V _{RWM}	Reverse Working Voltage				5.0	V
V _{BR}	Reverse Breakdown Voltage	I _T = 1mA,	6.0			V
I _R	Reverse Leakage Current	V _{RWM} = 5V,			100	nA
V _F	Diode Forward Voltage	I _F = 15mA		0.85	1.2	V
V _C	Clamping Voltage	I _{PP} = 1A, tp =8/20μs,			10	V
		I _{PP} = 2.5A, tp =8/20μs,			13	V
I _{PP}	Peak Pulse Current	tp =8/20μs			2.5	A
C _J	Junction Capacitance	V _R = 0V, f = 1MHz,		15	20	pF

Junction capacitance is measured in VR=0V,F=1MHz

Symbol	Parameter
V _{RWM}	Working Peak Reverse Voltage
V _{BR}	Breakdown Voltage @ I _T
V _C	Clamping Voltage @ I _{PP}
I _T	Test Current
I _{RM}	Leakage current at V _{RWM}
I _{PP}	Peak pulse current
C _O	Off-state Capacitance
C _J	Junction Capacitance

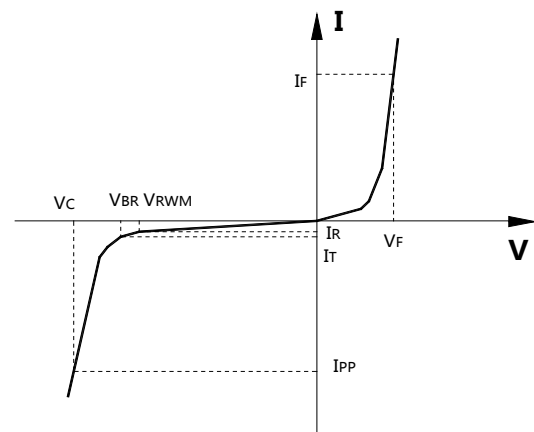

➤ Typical Characteristics

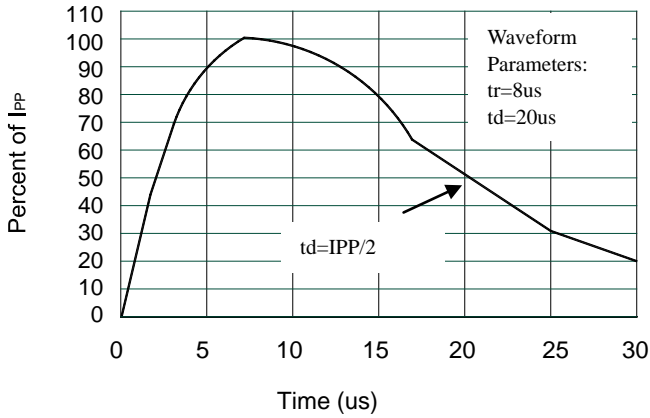

Pulse Waveform

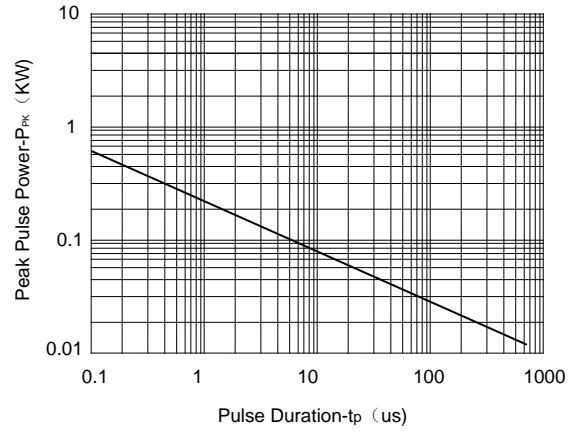

Non-Repetitive Peak Pulse Power vs. Pulse Time

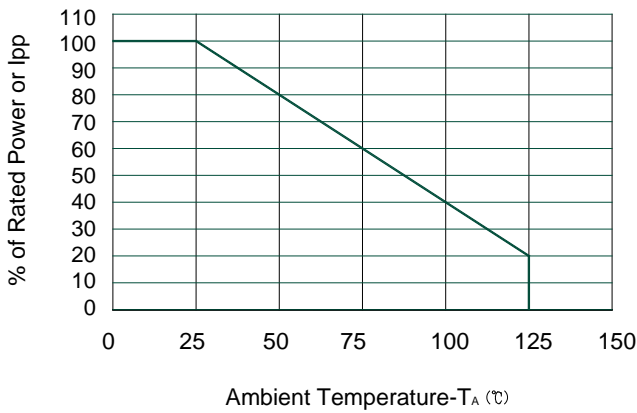

Power Derating Curve

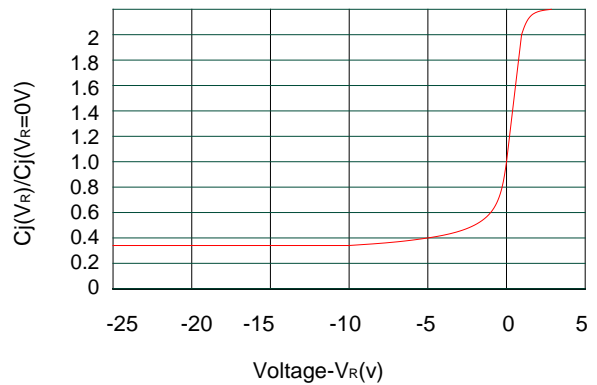

Junction Capacitance vs. Reverse Voltage

➤ Typical applications

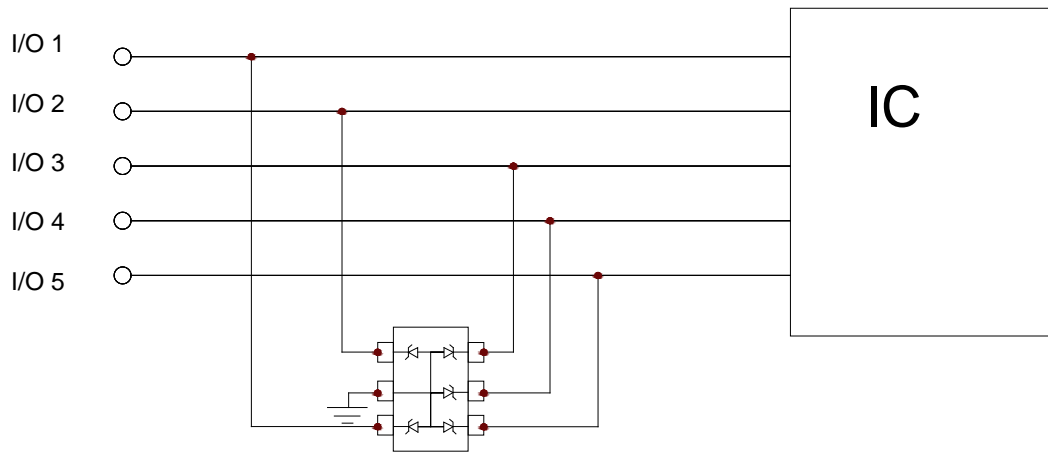

Device Connection for Protection of Five Data Lines

The SMF05C is designed to protect up to five unidirectional data lines. The device is connected as follows:

Unidirectional protection of five I/O lines is achieved by connecting pins 1, 3, 4, 5 and 6 to the data lines. Pin 2 is connected to ground. The ground connection should be made directly to the ground plane for best results. The path length is kept as short as possible to reduce the effects of parasitic inductance in the board traces.

➤ Package Information (SOT-363)

Mechanical Data

- Case: SOT-363
- Case Material: Molded Plastic. UL Flammability

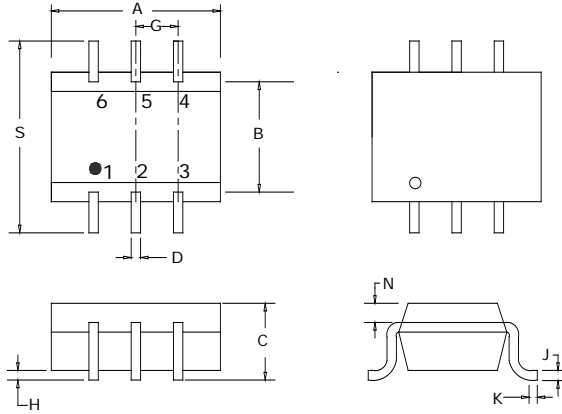

Dim	Millimeters		Inches	
	MIN	MAX	MIN	MAX
A	2.00	2.20	0.079	0.087
B	1.15	1.35	0.045	0.053
C	0.90	1.10	0.035	0.043
D	0.15	0.35	0.006	0.014
G	0.65BSC		0.026BSC	
H	--	0.10	--	0.004
J	0.08	0.15	0.003	0.006
K	0.15	0.35	0.006	0.014
N	0.20REF		0.008R EF	
S	2.15	2.45	0.085	0.096

Recommended Pad outline

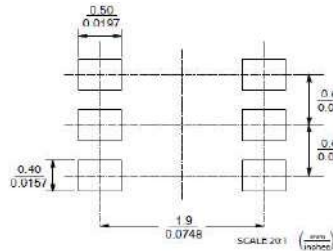

SOT-363 Reel Dim

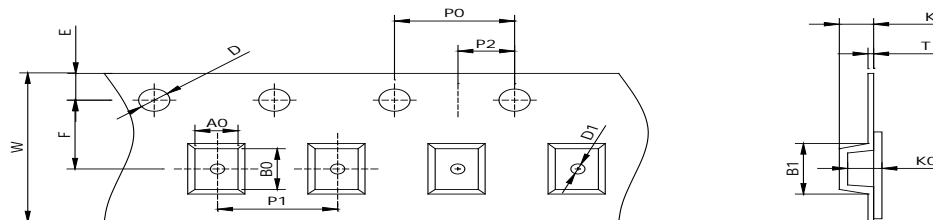

Package	Chip Size	Pocket Size B0×A0×K0(mm)	Tape Width	Reel Diameter	Quantity Per Reel	P0	P1
SOT-363	2.20×2.45×1.10	2.30×2.55×1.20	8mm	178mm(7")	3000	4mm	4mm
D0	D1	E	F	K	T	W	
1.5mm	1.0mm	1.75mm	3.5mm	1.15mm	0.2mm	8mm	

➤ Ordering Information

Part Number	Description	Quantity
SMF05C	SOT-363 Reel	3000 pcs

DISCLAIMER

- The information in this document and any product described herein are subject to change without notice and should not be construed as a commitment by Paceleader, Paceleader reserve the right to make changes to the information in this document.
- Though Paceleader make effort to improve product quality and reliability, Product can malfunction and fail due to their inherent electrical sensitivity and vulnerability to physical stress, it is the responsibility of the customer, when utilizing Paceleader products, to comply with the standards of safety in making a safe design for entire system and to avoid situation in which a malfunction or failure., In developing a new designs, customer should ensure that the device which shown in this documents are used within specified operatingranges.
- The information contained herein is presented only as a guide for the applications of our products. No responsibility is assumed by Paceleader for any infringements of patents or other rights of the third parties which may result from its use.