

### ➤ General Description

This PAN26TB14QB N-Channel enhancement mode power field effect transistor is the high density trench technology and this advanced technology can provide excellent  $R_{ds(On)}$  performance and efficiency for power switching and load switching application., this device also comply with the RoHS and Green Product requirement with full function reliability approved.

### ➤ Feature

- Green Device Available
- Super Low Gate Charge
- Excellent  $CdV/dt$  effect decline
- Advanced high cell density Trench technology
- SOT-223 package design

### ➤ SOT-223

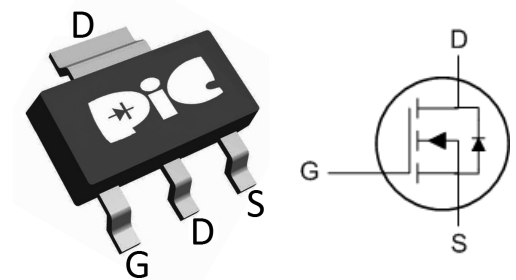

### ➤ Application

- Motor and Load Control
- Power Management in White LED System
- Push Pull Converter
- LCD TV Inverter & AD/DC Inverter Systems.

### ➤ Absolute Maximum Ratings

Parameter	Symbol	Maximum Ratings	Unit
Drain-Source Voltage	$V_{DS}$	100	V
Gate-Source Voltage	$V_{GS}$	$\pm 20$	V
Continuous Drain Current	$I_D$	$T_A=25^\circ C$	3.3
		$T_A=70^\circ C$	2.6
Pulsed Drain Current	$I_{DM}$	13	A
Maximum Power Dissipation	$P_D$	$T_A=25^\circ C$	2.9
		$T_A=70^\circ C$	1.9
Operating Junction Temperature	$T_J$	150	$^\circ C$
Storage Temperature Range	$T_{stg}$	-55 to 150	$^\circ C$
Thermal Resistance-Junction to Ambient	$R_{\theta JA}$	42	$^\circ C/W$

\*The device mounted on 1in<sup>2</sup> FR4 board with 2 oz copper

### ➤ Electrical Characteristics ( $T_J=25^\circ C$ Unless otherwise noted)

Symbol	Parameter	Limit	Min	Typ	Max	Unit
<b>STATIC</b>						
$V_{BR(DSS)}$	Drain-Source Breakdown Voltage	$V_{GS}=0V$ , $I_D=250 \mu A$	100			V
$V_{GS(th)}$	Gate Threshold Voltage	$V_{DS}=V_{GS}$ , $I_D=250 \mu A$	1.0		3.0	V
$I_{GSS}$	Gate Leakage Current	$V_{DS}=0V$ , $V_{GS}=\pm 20V$			$\pm 100$	nA
$I_{DSS}$	Zero Gate Voltage Drain Current	$V_{DS}=80V$ , $V_{GS}=0V$			1	$\mu A$
$R_{DS(ON)}$	Drain-Source On-Resistance <sup>a</sup>	$V_{GS}=10V$ , $I_D=3A$		140	166	m $\Omega$
		$V_{GS}=4.5V$ , $I_D=2.4A$		165	213	
$V_{SD}$	Diode Forward Voltage	$I_S=2.5A$ , $V_{GS}=0V$		0.8	1.2	V
<b>DYNAMIC</b>						
$Q_g$	Total Gate Charge	$V_{DS}=80V$ , $V_{GS}=10V$ , $I_D=2.5A$		19.2		nC
$Q_g$	Total Gate Charge	$V_{DS}=80V$ , $V_{GS}=4.5V$ , $I_D=2.5A$		11.2		
$Q_{gs}$	Gate-Source Charge			3.4		
$Q_{gd}$	Gate-Drain Charge			6.1		
$C_{iss}$	Input capacitance	$V_{DS}=15V$ , $V_{GS}=0V$ , $f=1.0MHz$		849		pF
$C_{oss}$	Output Capacitance			57		
$C_{rss}$	Reverse Transfer Capacitance			44		
$t_{d(on)}$	Turn-On Delay Time	$V_{DS}=50V$ , $R_L=10\Omega$ $V_{GS}=10V$ , $R_G=6\Omega$ $I_D=5A$		12.6		ns
$t_r$	Turn-On Rise Time			6		
$t_{d(off)}$	Turn-Off Delay Time			32.5		
$t_f$	Turn-Off Fall Time			4.3		

Notes: a. Pulse test: pulse width  $\leq 300\mu s$ , duty cycle  $\leq 2\%$ , Guaranteed by design, not subject to production testing.

## ➤ Typical Characteristics

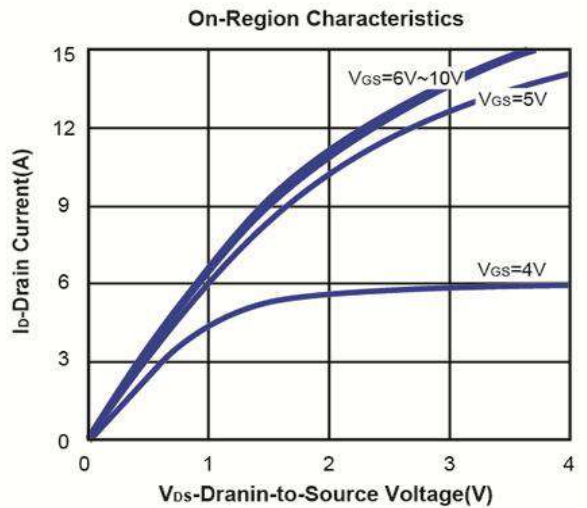
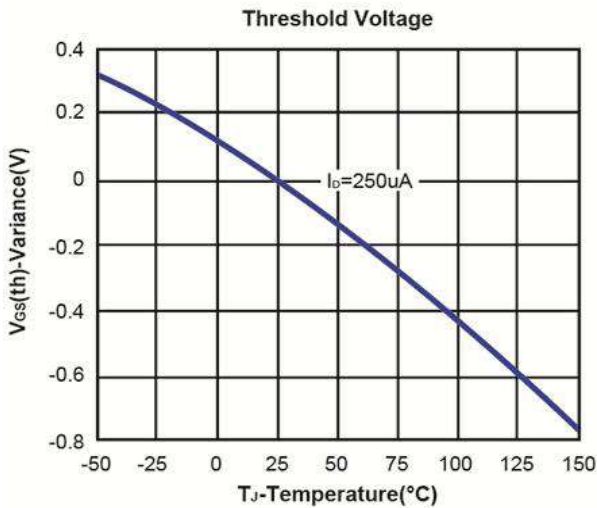
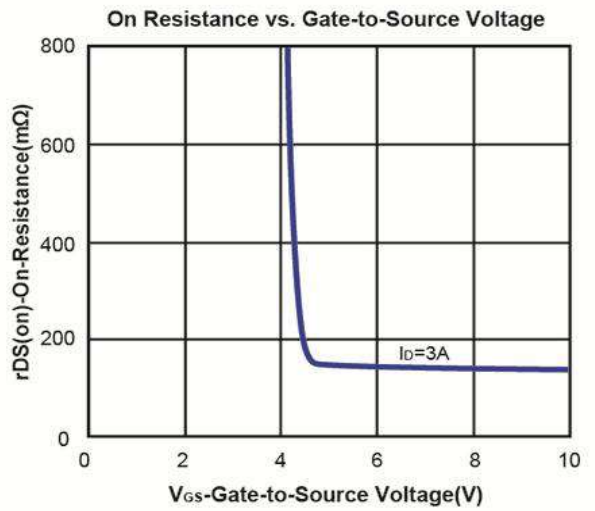
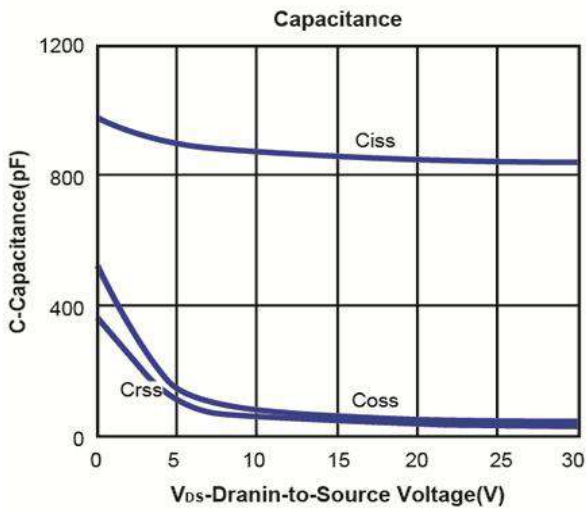
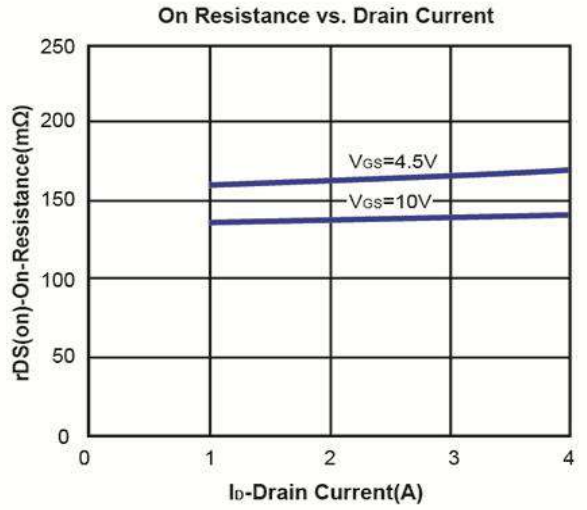
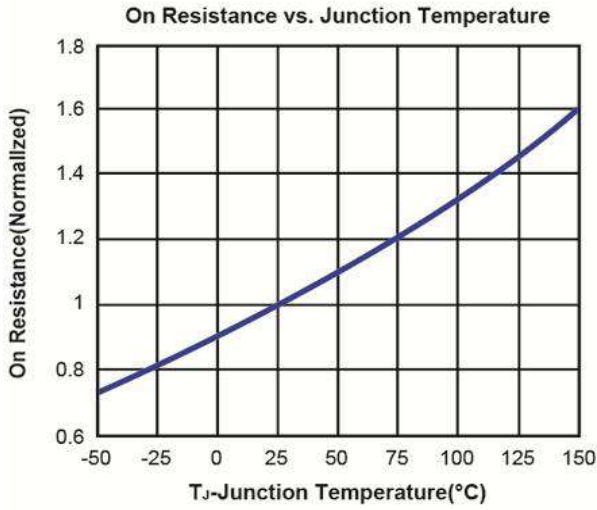

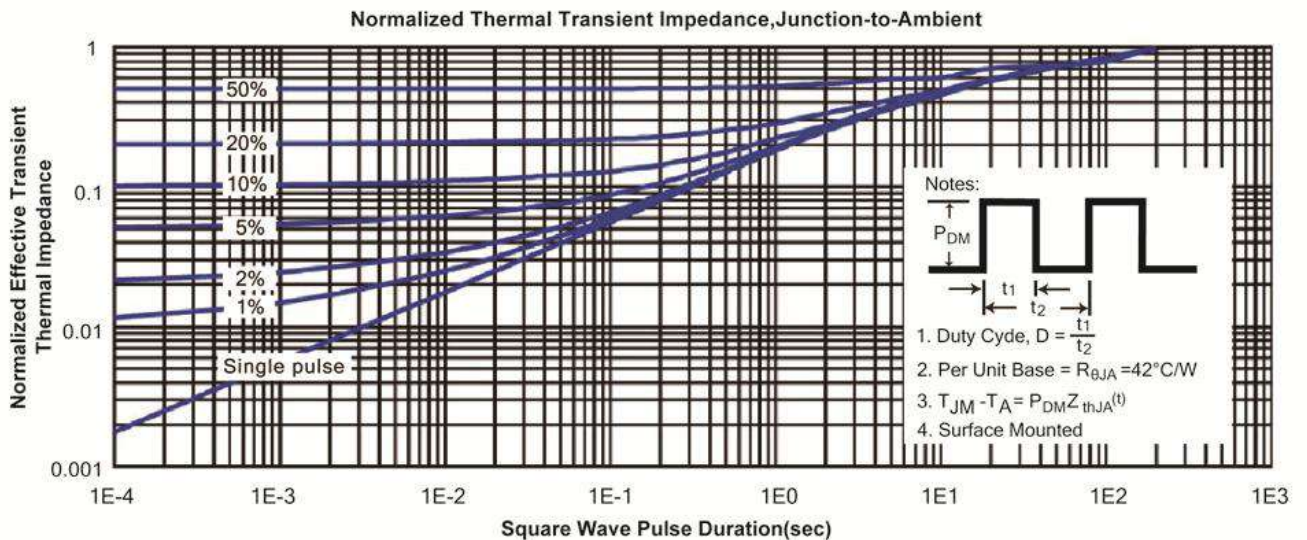
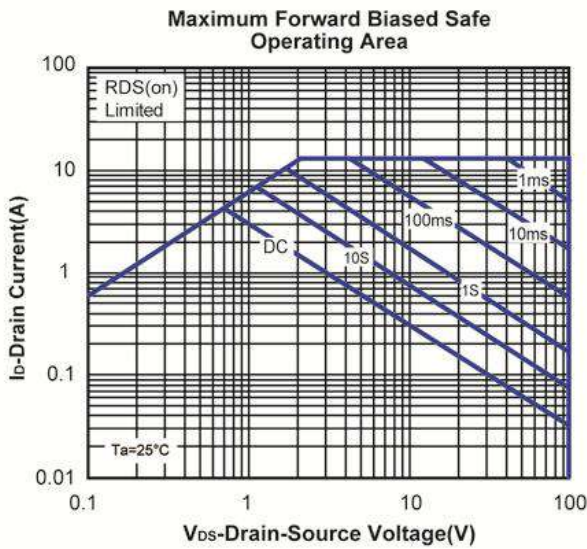
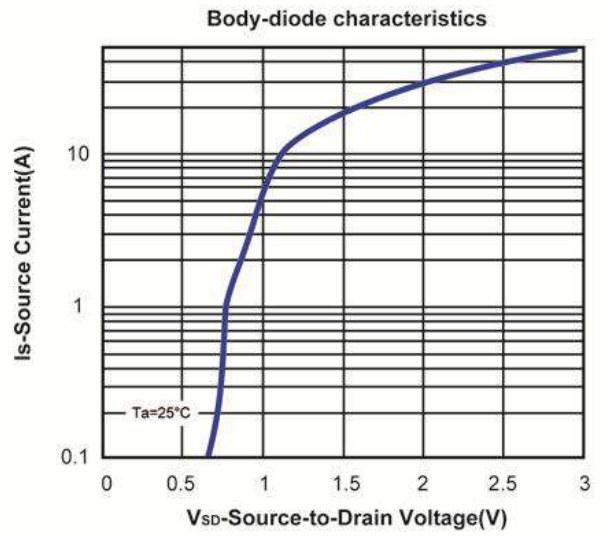
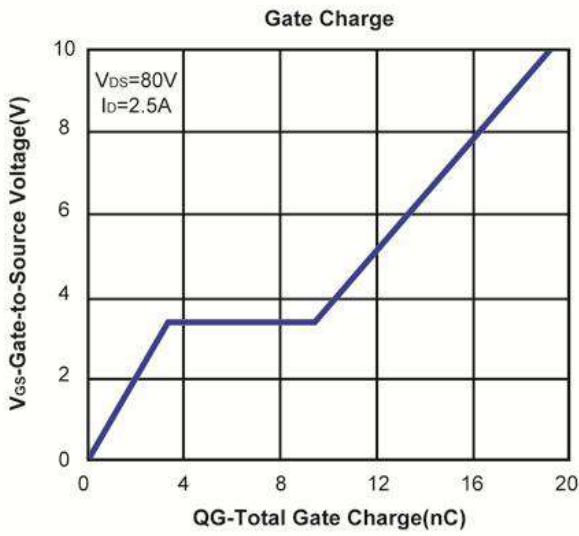

## ➤ Recommand IR Reflow Soldering Thermal Profile



Profile Feature	Pb-Free Assembly Profile
Temperature Min. (T <sub>smin</sub> )	150°C
Temperature Max. (T <sub>smax</sub> )	200°C
Time (t <sub>s</sub> ) from (T <sub>smin</sub> to T <sub>smax</sub> )	60-120 seconds
Average Ramp-up Rate (t <sub>L</sub> to t <sub>P</sub> )	3°C/second max.
Liquidous Temperature (T <sub>L</sub> )	217°C
Time (t <sub>L</sub> ) Maintained Above (T <sub>L</sub> )	60 – 150 seconds
Peak Temperature	260°C +0°C / -5°C
Time (t <sub>P</sub> ) within 5°C of actual Peak Temperature	30 seconds
Ramp-down Rate (T <sub>P</sub> to T <sub>L</sub> )	6°C/second max
Time 25°C to Peak Temperature	8 minutes max.

## ➤ Ordering Information

Part Number	Description	Quantity
PAN26TB14QB	SOT-223 Reel	3000 pcs

### ➤ Package Information ( SOT-223 )

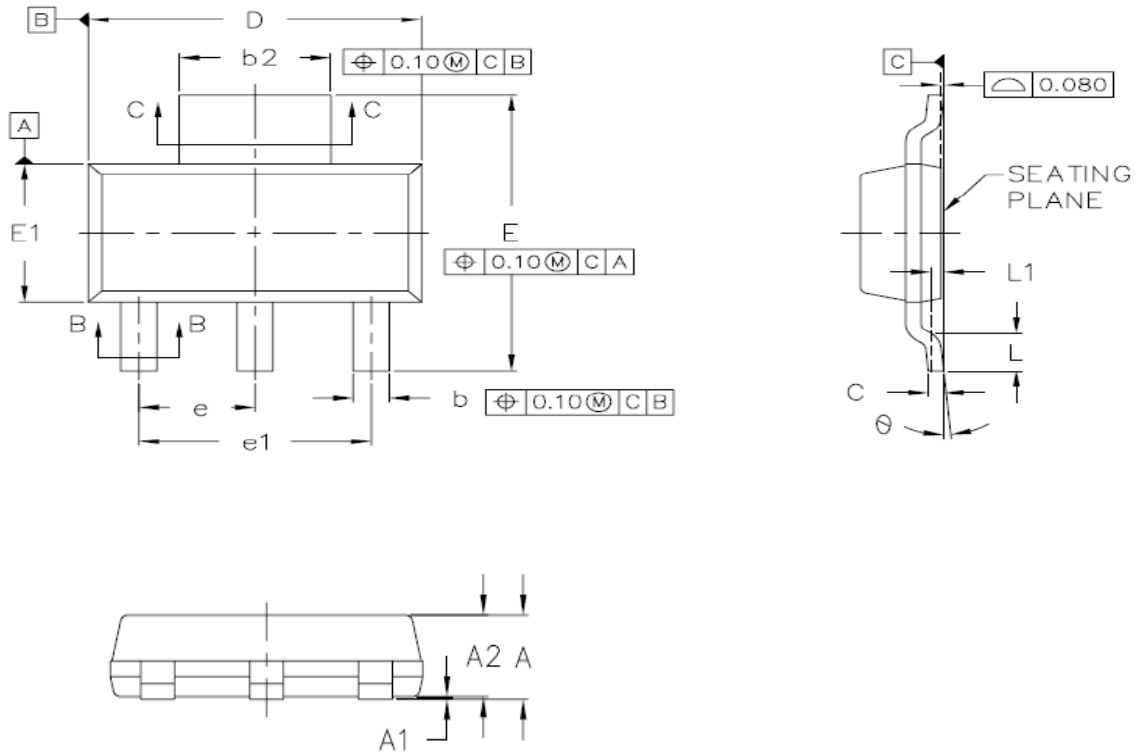

DIMENSIONS	COMMON			
	MM		INCH	
	MIN.	MAX.	MIN.	MAX.
A	—	1.80	—	0.071
A1	0.02	0.10	0.001	0.004
A2	1.50	1.70	0.059	0.067
b	0.66	0.84	0.026	0.033
b1	0.60	0.79	0.024	0.031
b2	2.90	3.10	0.114	0.122
b3	2.84	3.05	0.112	0.120
c	0.23	0.35	0.009	0.014
c1	0.23	0.33	0.009	0.013
D	6.30	6.70	0.248	0.264
E	6.70	7.30	0.264	0.287
E1	3.30	3.70	0.130	0.146
e	2.30 BSC.		0.091 BSC.	
e1	4.60 BSC.		0.182 BSC.	
L	0.81	—	0.032	—
L1	0.25 BSC.		0.010 BSC.	
θ	0°	10°	0°	10°

## DISCLAIMER

- The information in this document and any product described herein are subject to change without notice and should not be construed as a commitment by Paceleader, Paceleader reserve the right to make changes to the information in this document.
- Though Paceleader make effort to improve product quality and reliability, Product can malfunction and fail due to their inherent electrical sensitivity and vulnerability to physical stress, it is the responsibility of the customer, when utilizing Paceleader products, to comply with the standards of safety in making a safe design for entire system and to avoid situation in which a malfunction or failure., In developing a new designs, customer should ensure that the device which shown in this documents are used within specified operatingranges.
- The information contained herein is presented only as a guide for the applications of our products. No responsibility is assumed by Paceleader for any infringements of patents or other rights of the third parties which may result from its use.