

### ➤ General Description

PAE2530J are designed by bi-direction TVS diode, to protect high speed data interfaces. This product has been specifically designed to protect sensitive components which are connected to data and transmission lines from overvoltage caused by ESD (electrostatic discharge), CDE (Cable Discharge Events), and EFT (electrical fast transients). The TVS diode prevents over-voltage on the power line, protecting any downstream components. The low capacitance configuration allows the user to protect high-speed data or transmission lines. This device is optimized for ESD protection of portable electronics. They may be used to meet the ESD immunity requirements of IEC 61000-4-2, Level 4 ( $\pm 15\text{kV}$  air,  $\pm 8\text{kV}$  contact discharge).

### ➤ Feature

- Transient protection for high-speed data lines to IEC 61000-4-2 (ESD)  $\pm 15\text{kV}$  (air),  $\pm 8\text{kV}$  (contact) IEC 61000-4-4 (EFT) 40A (5/50ns)
- Small package saves board space
- Protects up to four I/O lines & power line
- Low capacitance ( $< 3\text{pF}$ ) for high-speed interfaces
- Low leakage current and clamping voltage
- Low operating voltage: 5.0V
- Solid-state silicon-avalanche technology

### ➤ SOT-363

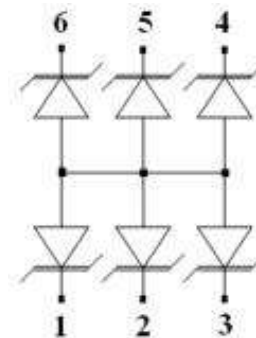
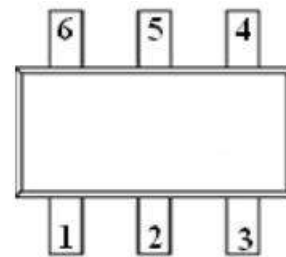

### ➤ Application

- USB 2.0 Power and Data Line Protection
- Monitors and Flat Panel Displays
- Digital Visual Interface (DVI)
- 10/100/1000 Ethernet
- Notebook Computer
- SIM Ports
- ATM Interface
- IEEE 1394 Firewire Ports Cellular
- Handsets & Accessories Portable
- Instrumentation
- Digital Cameras
- Video Graphics Cards

➤ **Maximum Ratings (T<sub>A</sub>=25°C Unless otherwise specified)**

Parameter	Symbol	Typical	Unit
Peak Pulse Power ( t <sub>p</sub> = 8/20 μs )	P <sub>pk</sub>	150	W
Maximum Peak Pulse Current ( t <sub>p</sub> = 8/20 μs )	I <sub>PP</sub>	6	A
ESD per IEC 61000 – 4 – 2 (Air)	V <sub>PP</sub>	±15	KV
ESD per IEC 61000 – 4 – 2 (Contact )	V <sub>PP</sub>	±8	KV
Operating Junction Temperature	T <sub>J</sub>	-55 ~ 125	°C
Storage Temperature Range	T <sub>STG</sub>	-55 ~ 150	°C
Lead Soldering Temperature	T <sub>L</sub>	260 ( 10sec )	°C

➤ **Electrical Characteristics (T<sub>A</sub>=25°C Unless otherwise specified)**

Parameter	Symbol	Conditions	Min.	Typ	Max.	Unit
Reverse Stand – Off Voltage	V <sub>RWM</sub>	Pin 1 to 2 or 2 to 1			5	V
Reverse Breakdown Voltage	V <sub>BR</sub>	I <sub>t</sub> = 1mA	6			V
Reverse Leakage Current	I <sub>R</sub>	V <sub>RWM</sub> = 5V , T=25K		0.5	1	μA
Clamping Voltage	V <sub>C</sub>	I <sub>PP</sub> = 1A , t <sub>p</sub> = 8/20 μs Pin 1 to 2 or 2 to 1			13	V
Clamping Voltage	V <sub>C</sub>	I <sub>PP</sub> = 6 , t <sub>p</sub> = 8/20 μs Pin 1 to 2 or 2 to 1			15	V
Junction Capacitance	C <sub>j</sub>	V <sub>R</sub> = 0V , f = 1MHz		2	3	pF

### ➤ Typical Characteristics

**Non-Repetitive Peak Pulse Power vs. Pulse Time**

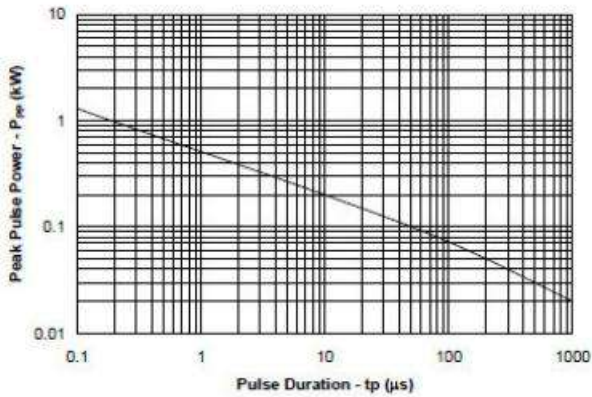

**Power Derating Curve**

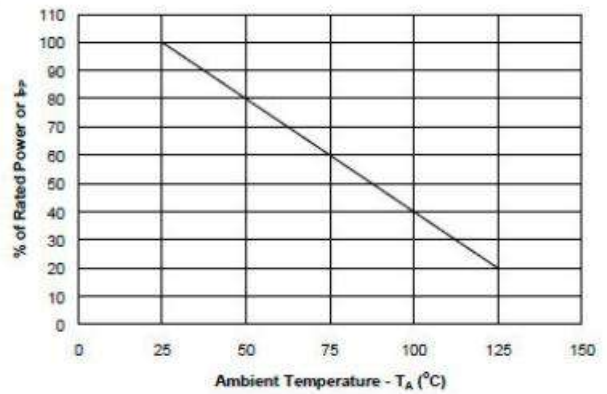

**Forward Voltage vs. peak Pulse Current**

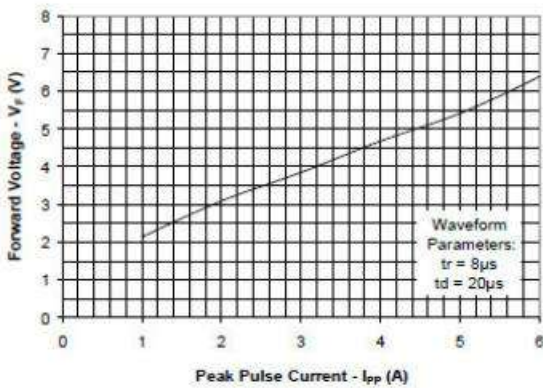

**Capacitance vs. Reverse Voltage (Normalized to 0V)**

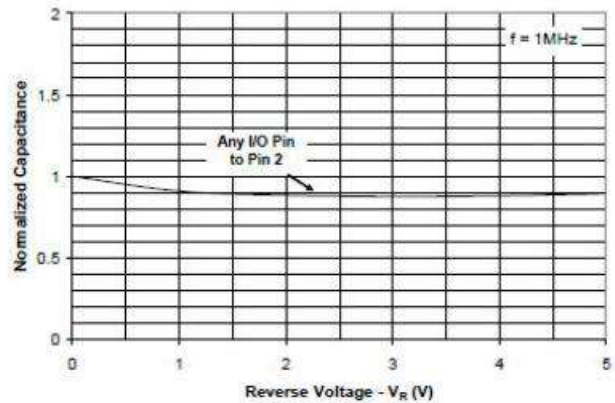

**Forward Voltage vs. peak Pulse Current**

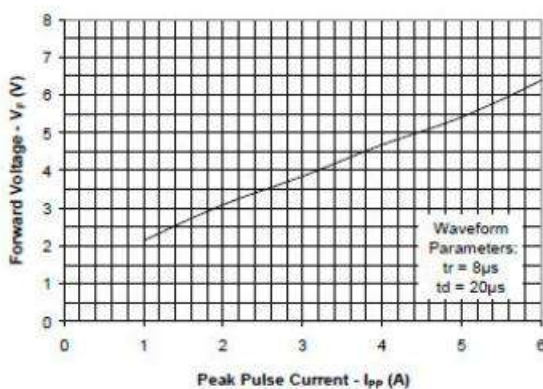

**Capacitance vs. Reverse Voltage (Normalized to 0V)**

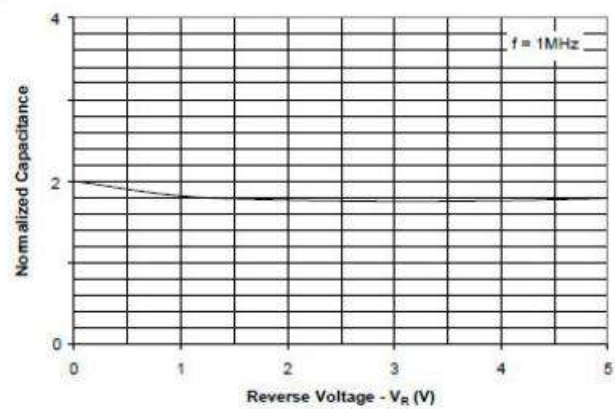

### ➤ Application Information

#### Device Connection for Protection of Five Data Lines

PAE2530J is designed to protect up to five bidirectional data lines. The device is connected as follows:

1. Bidirectional protection of five I/O lines is achieved by connecting pins 1, 3, 4, 5, and 6 to the data lines. Pin 2 is connected to ground. The ground connection should be made directly to the ground plane for best results. The path length is kept as short as possible to reduce the effects of parasitic inductance in the board traces.

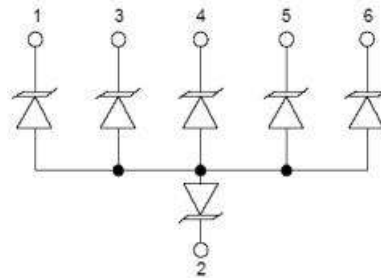

#### Circuit Board Layout Recommendations for Suppression of ESD

Good circuit board layout is critical for the suppression of ESD induced transients. The following guidelines are recommended:

1. Place the TVS near the input terminals or connectors to restrict transient coupling.
2. Minimize the path length between the TVS and the protected line.
3. Minimize all conductive loops including power and ground loops.
4. The ESD transient return path to ground should be kept as short as possible.
5. Never run critical signals near board edges.
6. Use ground planes whenever possible.

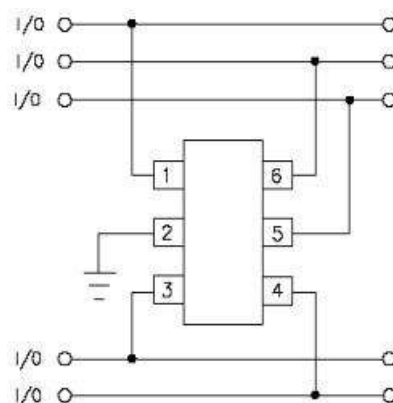

### ➤ Application Information

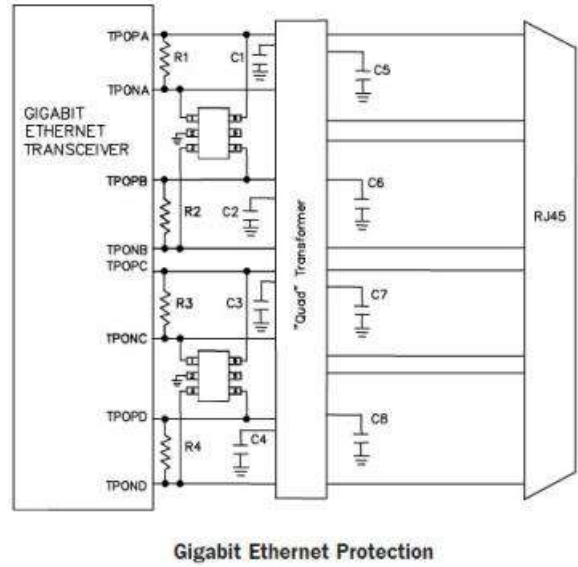
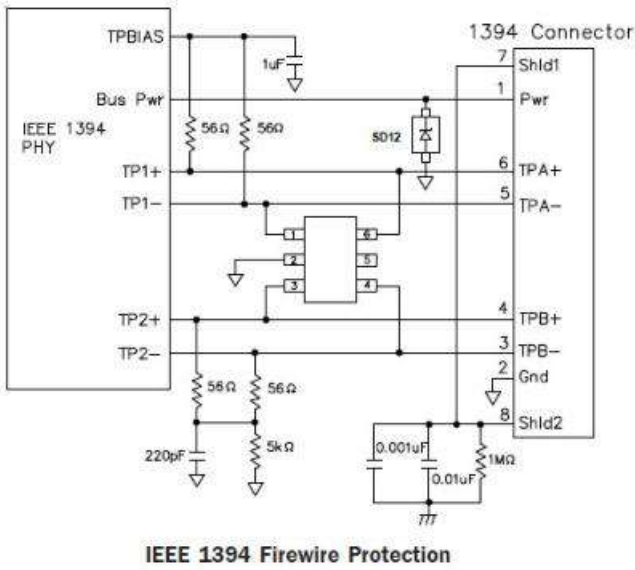
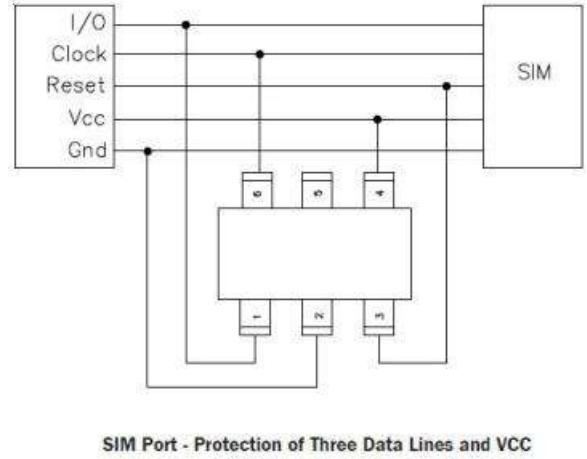
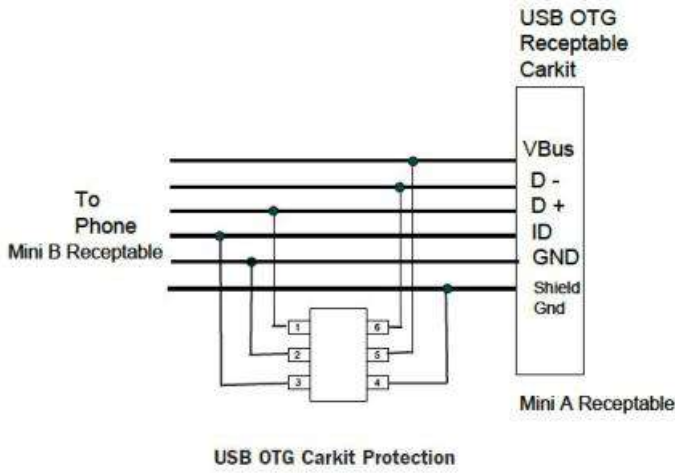

### ➤ Package Information (SOT-363)

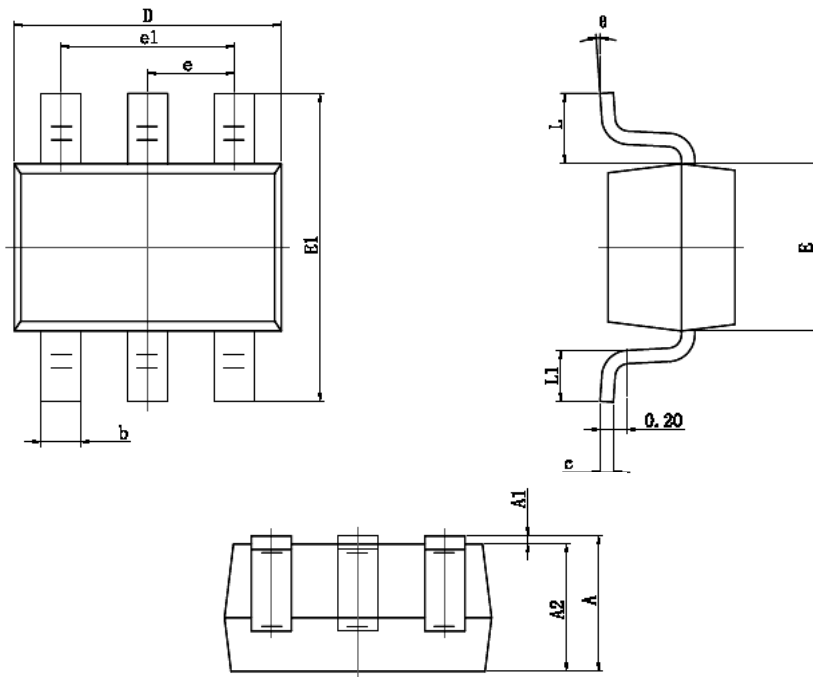

Symbol	Dimensions In Millimeters		Dimensions In Inches	
	Min	Max	Min	Max
A	0.900	1.100	0.035	0.043
A1	0.000	0.100	0.000	0.004
A2	0.900	1.000	0.035	0.039
b	0.150	0.350	0.006	0.014
c	0.080	0.150	0.003	0.006
D	2.000	2.200	0.079	0.087
E	1.150	1.350	0.045	0.053
E1	2.150	2.450	0.085	0.096
e	0.650 TYP		0.026 TYP	
e1	1.200	1.400	0.047	0.055
L	0.525 REF		0.021 REF	
L1	0.260	0.460	0.010	0.018
θ	0°	8°	0°	8°

### ➤ Ordering Information

Part Number	Description	Quantity
PAE2530J	SOT-363 Reel	3000 pcs

## **DISCLAIMER**

- The information in this document and any product described herein are subject to change without notice and should not be construed as a commitment by Paceleader, Paceleader reserve the right to make changes to the information in this document.
- Though Paceleader make effort to improve product quality and reliability, Product can malfunction and fail due to their inherent electrical sensitivity and vulnerability to physical stress, it is the responsibility of the customer, when utilizing Paceleader products, to comply with the standards of safety in making a safe design for entire system and to avoid situation in which a malfunction or failure., In developing a new designs, customer should ensure that the device which shown in this documents are used within specified operatingranges.
- The information contained herein is presented only as a guide for the applications of our products. No responsibility is assumed by Paceleader for any infringements of patents or other rights of the third parties which may result from its use.