

### General Description

The PAE0514DTG provides a typical line to line capacitance of 0.80pF and low insertion loss up to 5GHz providing greater signal integrity making it ideally suited for USB 2.0/3.0 applications, such as Digital TVs, DVD players, Computing, set-top boxes and MDDI applications in mobile computing devices.

It has been specifically designed to protect sensitive components which are connected to high-speed data and transmission lines from overvoltage caused by ESD(electrostatic discharge), CDE (Cable Discharge Events),and EFT (electrical fast transients).

### Features

- Protects four I/O lines and one Vcc line
- Low capacitance
- Working voltages : 5V
- Low leakage current
- Low capacitance (<1.0pF) for high-speed interfaces
- No insertion loss to 5.0GHz
- Response Time is < 1 ns
- Meets MSL 1 Requirements
- Solid-state silicon avalanche technology
- ROHS compliant

### SOT-23-6L

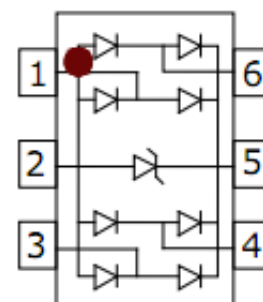
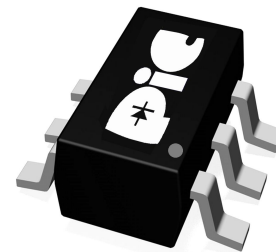

### Main applications

- Digital Visual Interface (DVI)
- 10/100/1000 Ethernet
- USB 1.1/2.0/OTG
- IEEE 1394 Firewire Ports
- Projection TV Monitors and Flat Panel Displays
- Notebook Computers
- Set Top Box
- Projection TV

### Protection solution to meet

- IEC61000-4-2 (ESD) ±15kV (air), ±8kV (contact)
- IEC61000-4-4 (EFT) 40A (5/50ns)

### Maximum ratings (Tamb=25°C Unless Otherwise Specified)

Parameter	Symbol	Value	Unit
Peak Pulse Power (tp=8/20μs waveform)	P <sub>PPP</sub>	80	Watts
Peak Pulse Current(tp=8/20μs waveform)	I <sub>PP</sub>	5	A
ESD Rating per IEC61000-4-2:	Contact	8	KV
	Air	15	
Lead Soldering Temperature	T <sub>L</sub>	260 (10 sec.)	°C
Operating Temperature Range	T <sub>J</sub>	-55 ~ 150	°C
Storage Temperature Range	T <sub>STG</sub>	-55 ~ 150	°C

Maximum ratings are those values beyond which device damage can occur. Maximum ratings applied to the device are individual stress limit values (not normal operating conditions) and are not valid simultaneously. If these limits are exceeded, device functional operation is not implied, damage may occur and reliability may be affected.

\*Other voltages may be available upon request.

1. Non-repetitive current pulse, per Figure 1.

### Electrical characteristics (Tamb=25°C Unless Otherwise Specified)

Symbol	Parameter	Conditions	Min.	Typ.	Max.	Units
V <sub>RWM</sub>	Reverse Working Voltage	Any I/O to Ground			5.0	V
V <sub>BR</sub>	Reverse Breakdown Voltage	I <sub>T</sub> = 1mA, Any I/O to Ground	6.0	7.4		V
I <sub>R</sub>	Reverse Leakage Current	V <sub>RWM</sub> = 5V, Any I/O to Ground			1	μA
V <sub>F</sub>	Diode Forward Voltage	I <sub>F</sub> = 15mA		0.85	1.2	V
V <sub>C</sub>	Clamping Voltage	I <sub>PP</sub> = 1A, tp =8/20μs, any I/O pin to Ground			9.0	V
		I <sub>PP</sub> = 5A, tp =8/20μs, any I/O pin to Ground		13	16	V
C <sub>J</sub>	Junction Capacitance	V <sub>R</sub> = 0V, f = 1MHz, between I/O pins		0.35	0.45	pF
		V <sub>R</sub> = 0V, f = 1MHz, any I/O pin to Ground		0.35	0.45	pF

Junction capacitance is measured in V<sub>R</sub>=0V,F=1MHz

Symbol	Parameter
V <sub>RWM</sub>	Working Peak Reverse Voltage
V <sub>BR</sub>	Breakdown Voltage @ I <sub>T</sub>
V <sub>C</sub>	Clamping Voltage @ I <sub>PP</sub>
I <sub>T</sub>	Test Current
I <sub>RM</sub>	Leakage current at V <sub>RWM</sub>
I <sub>PP</sub>	Peak pulse current
C <sub>O</sub>	Off-state Capacitance
C <sub>J</sub>	Junction Capacitance

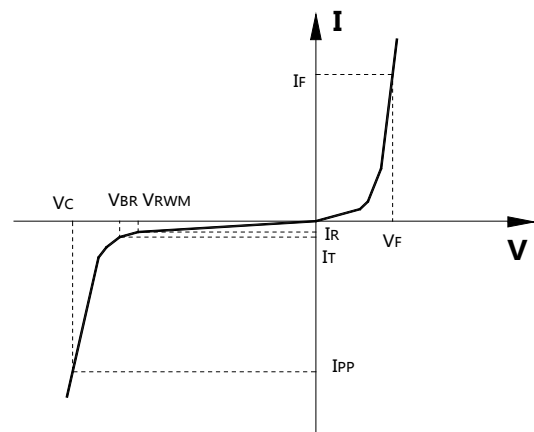

### Typical electrical characterist applications

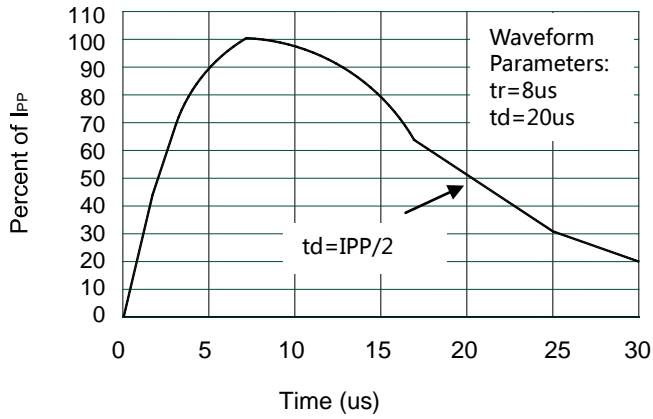

Pulse Waveform

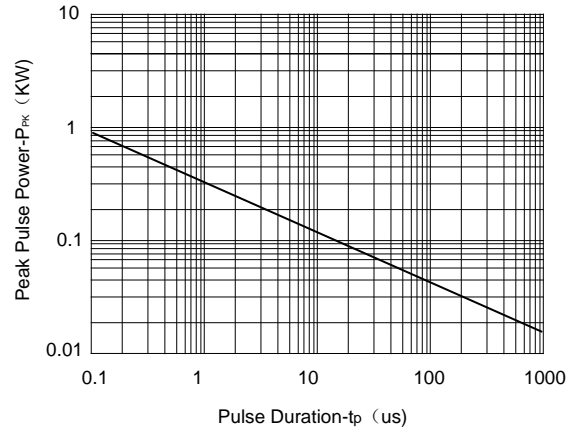

Non-Repetitive Peak Pulse Power vs. Pulse Time

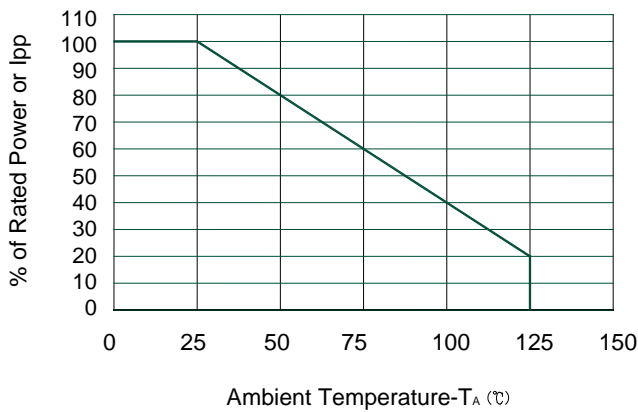

Power Derating Curve

### Typical applications

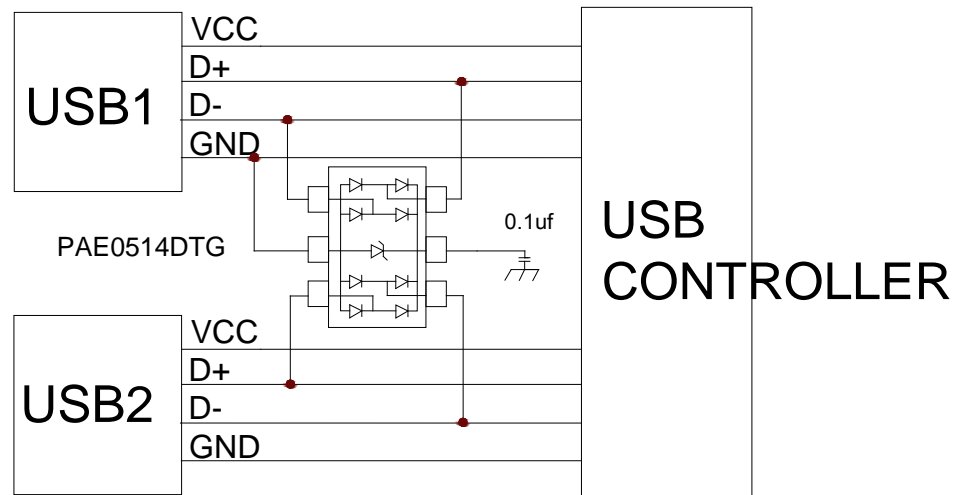

ESD protection for USB port

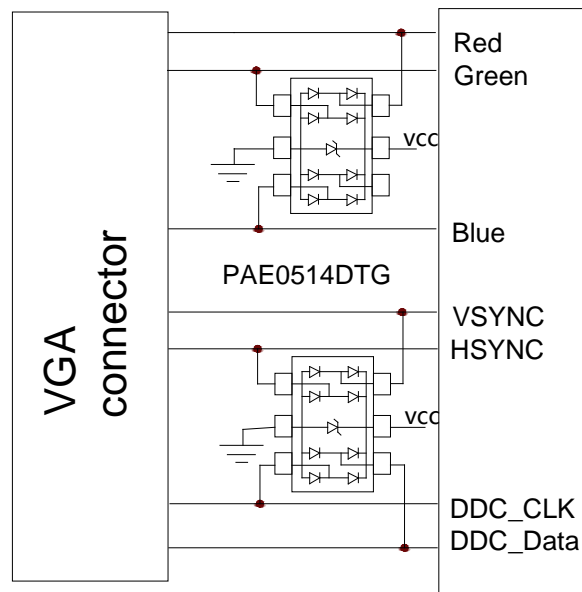

ESD protection for VGA port

### Ordering Information

Part Number	Description	Quantity
PAE0514DTG	SOT-23-6L Reel	3000 pcs

### Package Information

#### SOT-23-6L Mechanical Data

- Case Material: Molded Plastic. UL Flammability

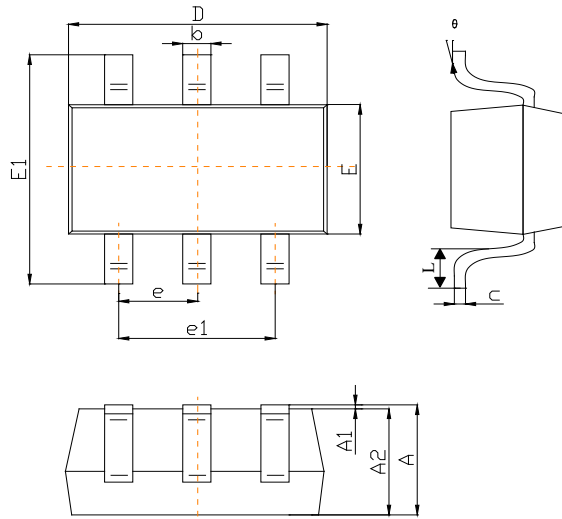

DIM	Millimeters		Inches	
	Min	Max	Min	Max
A	1.050	1.250	0.041	0.049
A1	0.000	0.100	0.000	0.004
A2	1.050	1.150	0.041	0.045
b	0.300	0.500	0.012	0.020
c	0.100	0.200	0.004	0.008
D	2.820	3.020	0.111	0.119
E	1.500	1.700	0.059	0.067
E1	2.650	2.950	0.104	0.116
e	0.950(BSC)		0.037(BSC)	
e1	1.800	2.000	0.071	0.079
L	0.300	0.600	0.012	0.024
θ	0	8°	0	8°

#### Recommended Pad outline

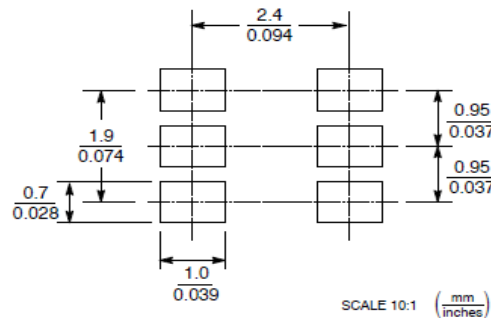

#### SOT23-6L Reel Dim

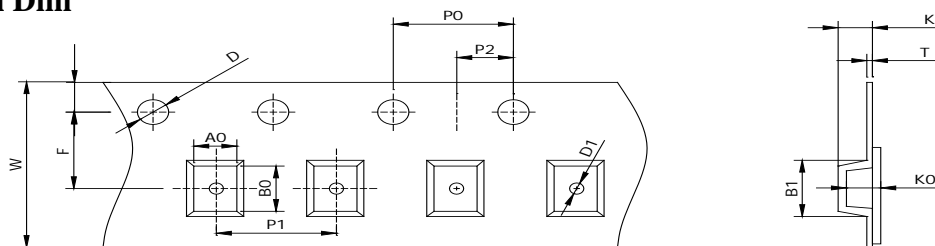

Package	Chip Size	Pocket Size B0×A0×K0(mm)	Tape Width	Reel Diameter	Quantity Per Reel	P0	P1
SOT23-6L	3.00×2.90×1.20	3.20×3.10×1.40	8mm	178mm(7")	3000	4mm	4mm
D0	D1	E	F	K	T	W	
1.5mm	1.0mm	1.75mm	3.5mm	1.25mm	0.2mm	8mm	

## **DISCLAIMER**

- The information in this document and any product described herein are subject to change without notice and should not be construed as a commitment by Paceleader, Paceleader reserve the right to make changes to the information in this document.
- Though Paceleader make effort to improve product quality and reliability, Product can malfunction and fail due to their inherent electrical sensitivity and vulnerability to physical stress, it is the responsibility of the customer, when utilizing Paceleader products, to comply with the standards of safety in making a safe design for entire system and to avoid situation in which a malfunction or failure., In developing a new designs, customer should ensure that the device which shown in this documents are used within specified operatingranges.
- The information contained herein is presented only as a guide for the applications of our products. No responsibility is assumed by Paceleader for any infringements of patents or other rights of the third parties which may result from its use.